

Data sheet Quadax® - double flange butterfly valve



REV01_0318

01

body details

butterfly valve:	bare shaft
pressure range:	0-2320 psi
orifice:	NPS 2-40
connection:	flange
body materials:	carbon steel, stainless steel, special material (duplex, inconell, bronze)
valve seat materials:	inconell, others on request
seal materials:	graphite / stainless steel, inconell, stainless steel, PTFE



Above stated body materials refer to the valve port connections that get in contact with the media only!

details needed

size
pipe connection
operating pressure
flow rate
Δp
closing time
media
process temperature
outside temperature



The valves' technical design is based on media and application requirements. This can lead to deviations from the general specifications shown on the data sheet with regards to the design, sealing materials and characteristics.



If order or application specifications are incomplete or imprecise there exists a risk of an incorrect technical design of the valve for the required application. As a consequence, the physical and / or chemical properties of the materials or seals used, may not be suitable for the intended application.

general specifications

ports	flange	ANSI 150 / 300 / 600 / 900
function	NC / NO / DA	depending upon actuator
pressure range	body pressure	0 to 2320 psi
	Δp standard shaft	754 psi in both directions
	Δp optional shaft	1450 psi in both directions
cv value	gal/min	see table
		ANSI class VI
leakage rate		A DIN EN 12266
		BS 6364
		Fire safe
flow direction	A \rightarrow B	as marked
switching time	s	size/4
process- and outside temperature	standard	14 °F to +842 °F
	with special materials	-454 °F to +1472 °F
limit switches		option
approvals		PED / Fire safe / BAM / TA Luft / ATEX in further
weight	lb	see table
additional equipment		upon request

cv-curve

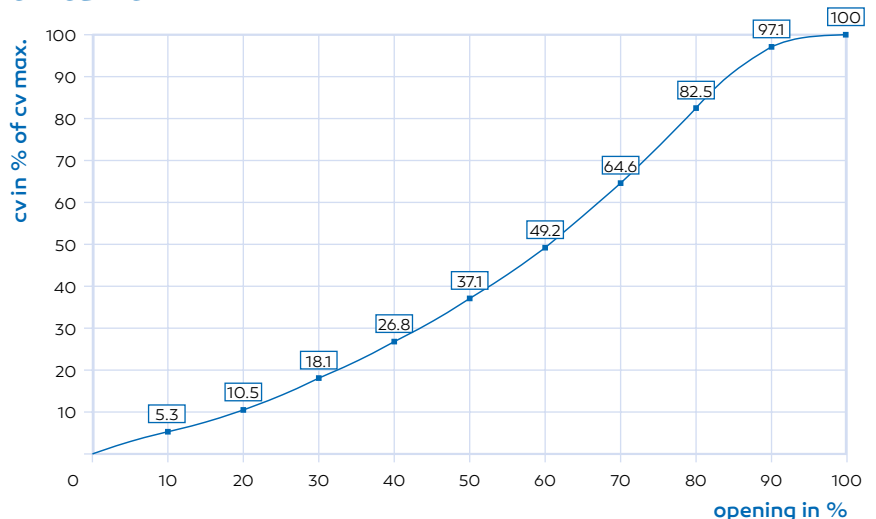

Data sheet Quadax® - double flange butterfly valve

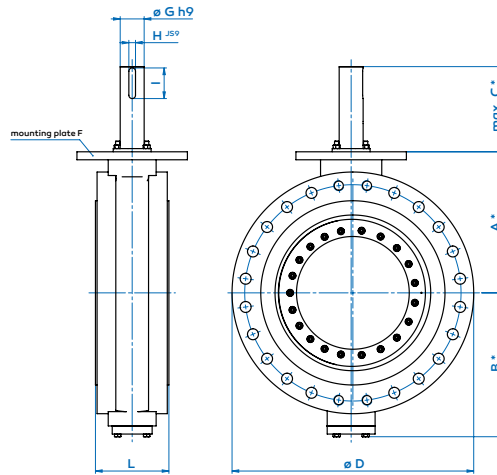

* dimensions for trim X only

Dimensions

size	(inch)	2	2½	3	4	5	6	8	10	12	14	16	18	20	24	28	30	32	36	40	
pipe cl to mounting plate	A	4.13	5.04	5.04	6.38	7.48	7.99	9.45	10.98	12.01	12.80	15.16	15.94	17.32	20.87	24.80	24.80	27.56	32.68	36.22	
pipe cl to cover screws	B	4.17	5.08	5.08	6.22	7.32	8.03	9.49	11.06	12.09	13.11	15.08	15.87	17.36	21.30	25.31	25.31	28.07	32.91	36.46	
bare shaft length for direct mounting	C	3.74	3.74	3.74	4.92	5.31	5.71	7.09	7.09	7.09	11.02	11.38	11.81	12.60	12.60	14.45	14.45	14.45	15.67	15.67	
bare shaft length for adapter	C	2.01	2.01	2.01	2.68	2.68	2.68	3.35	3.35	3.35	6.81	6.69	6.69	6.69	6.69	8.27	-	-	-	-	
flange diameter	ANSI 150	D	6.50	7.48	7.48	9.06	-	11.02	13.86	15.94	19.09	21.65	23.23	25.20	27.56	32.09	36.50	38.74	42.72	45.98	50.79
	ANSI 300	D	6.50	8.27	8.27	10.00	-	12.60	14.96	17.52	20.28	23.03	25.98	27.95	30.31	35.75	40.75	42.99	45.24	50.00	48.74
	ANSI 600	D	6.50	8.27	8.27	10.83	-	13.98	16.54	20.00	22.05	23.82	26.97	29.33	32.09	37.01	42.24	44.49	47.01	51.77	51.97
	ANSI 900	D	-	9.45	9.45	11.50	-	14.96	18.50	21.46	24.02	25.20	27.76	31.10	33.86	40.94	46.06	48.43	51.77	57.48	59.45
mounting plate F ISO 5211	(others on request)	F	F07	F07	F07	F10	F12	F14	F16	F16	F16	F25	F30	F30	F35	F35	F40	F40	F40	F48	F48
trim A	290 psi max.	G	-	-	-	-	-	-	-	1.57	1.77	1.97	2.17	2.17	2.76	3.54	3.54	3.94	4.33	4.72	
		H	-	-	-	-	-	-	-	0.47	0.55	0.55	0.63	0.63	0.79	0.98	0.98	1.10	1.26	1.26	
		I	-	-	-	-	-	-	-	1.77	2.36	2.36	3.15	3.15	3.54	4.53	4.53	4.92	5.51	6.30	
trim X (standard)	754 psi max.	G	0.55	0.71	0.71	0.79	0.87	1.26	1.26	1.57	1.77	2.17	2.56	2.76	2.95	3.54	4.33	4.33	5.12	5.91	6.30
		H	0.20	0.24	0.24	0.24	0.24	0.39	0.39	0.47	0.55	0.63	0.71	0.79	0.79	0.98	1.26	1.26	1.26	1.42	1.57
		I	0.98	1.10	1.10	1.10	1.57	1.57	1.57	1.77	2.36	3.15	3.46	3.54	3.54	4.53	5.51	5.51	7.09	7.09	7.87
trim B	1500 psi max.	G	-	-	-	-	-	1.77	2.17	2.56	2.95	3.54	3.74	4.33	5.12	5.91	5.91	7.09	7.48	8.66	
		H	-	-	-	-	-	0.55	0.63	0.71	0.79	0.98	0.98	1.26	1.42	1.42	1.77	1.77	1.97		
		I	-	-	-	-	-	2.36	3.15	3.46	3.54	115	4.92	5.51	7.09	7.09	8.66	9.84	11.02		
trim C	2250 psi max.	G	-	0.79	0.79	1.10	1.26	1.57	1.97	2.56	2.95	3.54	4.33	4.33	5.12	5.91	6.69	6.69	7.87	9.06	9.84
		H	-	0.24	0.24	0.31	0.39	0.47	0.55	0.71	0.79	0.98	1.26	1.26	1.26	1.42	1.57	1.57	1.77	1.97	2.20
		I	-	1.10	1.10	1.57	1.57	1.77	2.36	3.46	3.54	4.53	5.51	5.51	7.09	7.09	7.87	7.87	9.45	11.02	12.60
ISO 5752 R13 / DIN 3202 F16	ANSI 150/300	L	4.25	4.49	4.49	5.00	-	5.51	5.98	6.50	7.01	7.48	8.50	8.74	9.02	10.51	11.50	12.52	12.52	12.99	16.14
ISO 5752 R14 / DIN 3202 F4	ANSI 600/900	L	5.91	7.09	7.09	7.48	7.87	8.27	9.06	9.84	10.63	11.42	12.20	12.99	13.78	15.35	16.93	18.50	18.50	20.08	21.65
cv-value (gal/min)	trim A	Δp max. 290 psi	-	-	-	-	-	-	-	4462	6370	9237	12483	15024	24013	29620	37978	42003	55308	65269	
	trim X	Δp max. 754 psi	44	137	137	300	486	760	1680	2850	4314	5953	8513	11612	14091	22387	26838	31702	38771	50250	59765
	trim B	Δp max. 1500 psi	-	-	-	-	-	-	1458	2469	3698	5185	7305	10160	11913	19137	23053	25914	33293	45295	51679
	trim C	Δp max. 2250 psi	-	117	117	242	400	670	1353	2228	3402	4607	6580	9290	10979	17444	21199	24658	31138	40341	47523
weight (standard)	(approx. lb)	24	40	40	60	84	97	172	245	353	518	736	769	1049	1623	1900	2242	2509	3252	4766	